



**EBARA**

	Page
<b>- SPECIFICATIONS</b>	200
SELECTION CHART	201
PERFORMANCE CHART DWO 150	202
PERFORMANCE CHART DWO 200	203
PERFORMANCE CHART DWO 300	204
PERFORMANCE CHART DWO 400	205
<b>- CONSTRUCTIONS</b>	300
SECTIONAL VIEW	300
MECHANICAL SEAL	301
DIAGRAM AND ELECTRIC CONNECTIONS	302
DIAGRAM AND ELECTRIC CONNECTIONS	303
<b>- DIMENSIONS</b>	400
PACKING AND WEIGHT	401
<b>- TECHNICAL DATA</b>	500

## SPECIFICATIONS

50 Hz

PUMP		
Liquid Handled	Type of liquid	Clean water
	Max temperature [°C]	90
Maximum working pressure [MPa]		0,8
Construction	Impeller	Open centrifugal type
	Shaft seal type	Mechanical seal
	Bearing	Sealed ball bearing
Pipe Connection	Suction	G 2 G 2½ (DWO 300-400)
	Discharge	G 2
Material	Casing	AISI 304
	Impeller	AISI 304
	Casing cover	AISI 304
	Shaft seal	Ceramic/Carbon/NBR
	Casing cover	AISI 304
	Shaft	AISI 304 (Part in contact with liquid)
	Bracket	Aluminium
Applicable standard of test		ISO 9906 – Annex A

MOTOR		
Type	Electric - TEFC	
	Single Phase	Three Phase
No. of Poles	2	
Synchronous speed [min <sup>-1</sup> ]	3000	
Insulation Class	F	
Protection degree	IP 55	
Power rating	[kW]	1.1 ÷ 1.5
	[HP]	1.5 ÷ 2
Frequency [Hz]	50	
Voltage [V]	230 ±10%	230/400 ±10%
Capacitor	Built in	-
Over load protection	Built in	Provided by the user
Casing material	Aluminium	
Base material/motor support	Aluminium	
Dimensions of cable entry	PG11 - PG13.5 (See page 400)	

## SELECTION CHART

50Hz

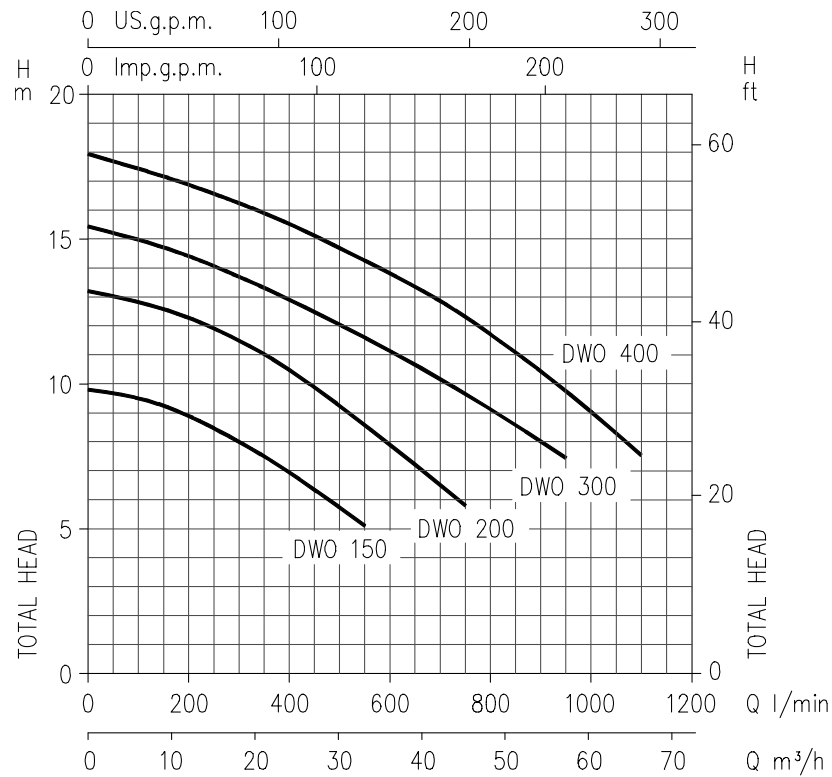

Type pumps		kW	HP	Q=Capacity								
Single Phase 230 V 50 Hz	Three Phase 230/400 V 50 Hz			l/min	100	200	300	400	550	750	950	1100
				m³/h	6	12	18	24	33	42	57	66
H=Total manometric head in meters												
DWO 150 M	DWO 150	1.1	1.5	9.5	8.9	7.9	6.9	5.1	-	-	-	-
DWO 200 M	DWO 200	1.5	2	12.7	12.3	11.5	10.5	8.6	5.8	-	-	-
-	DWO 300	2.2	3	15	14.5	13.8	12.9	11.7	9.7	7.5	-	-
-	DWO 400	3	4	17.5	16.9	16.3	15.6	14.3	12.4	9.8	7.6	-

### TYPE KEY:

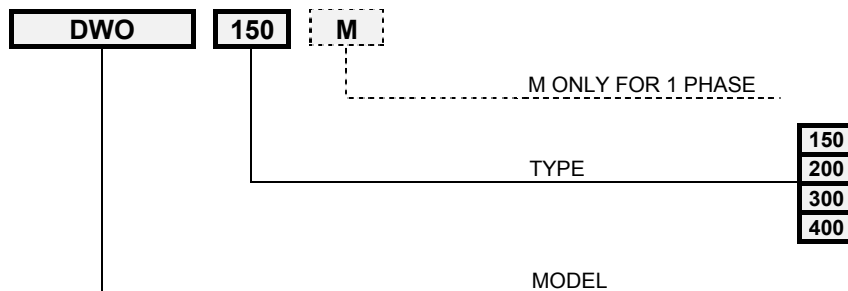

DWO 150 (1.1 kW) - Impeller diameter = 88 mm

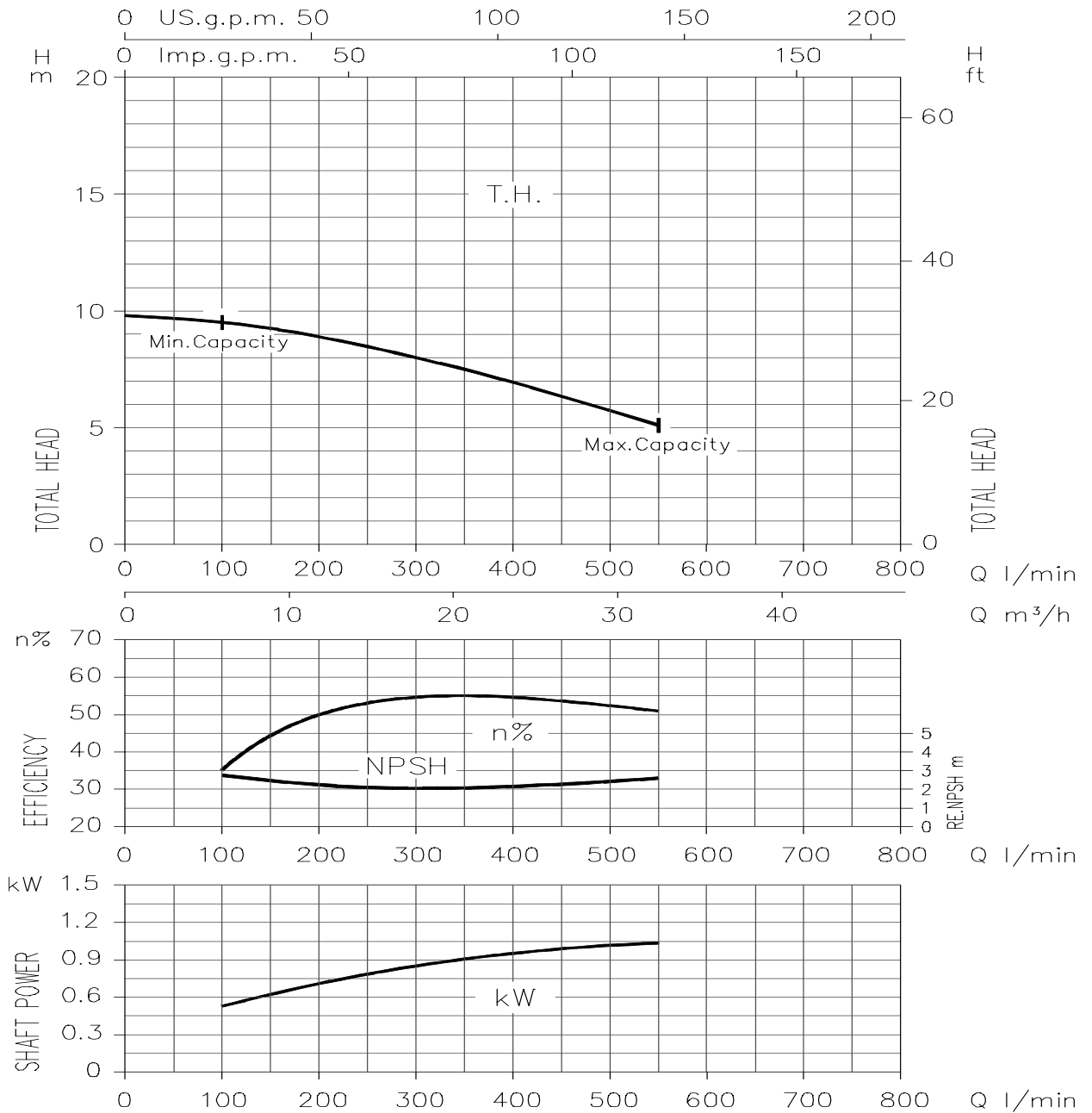

Rotation speed:  $\approx 2800 \text{ min}^{-1}$   
 Test fluid: clean water at  $20^\circ\text{C}$   
 Applicable standard of test: ISO 9906 – Annex A

DWO 200 (1.5 kW) - Impeller diameter = 103 mm

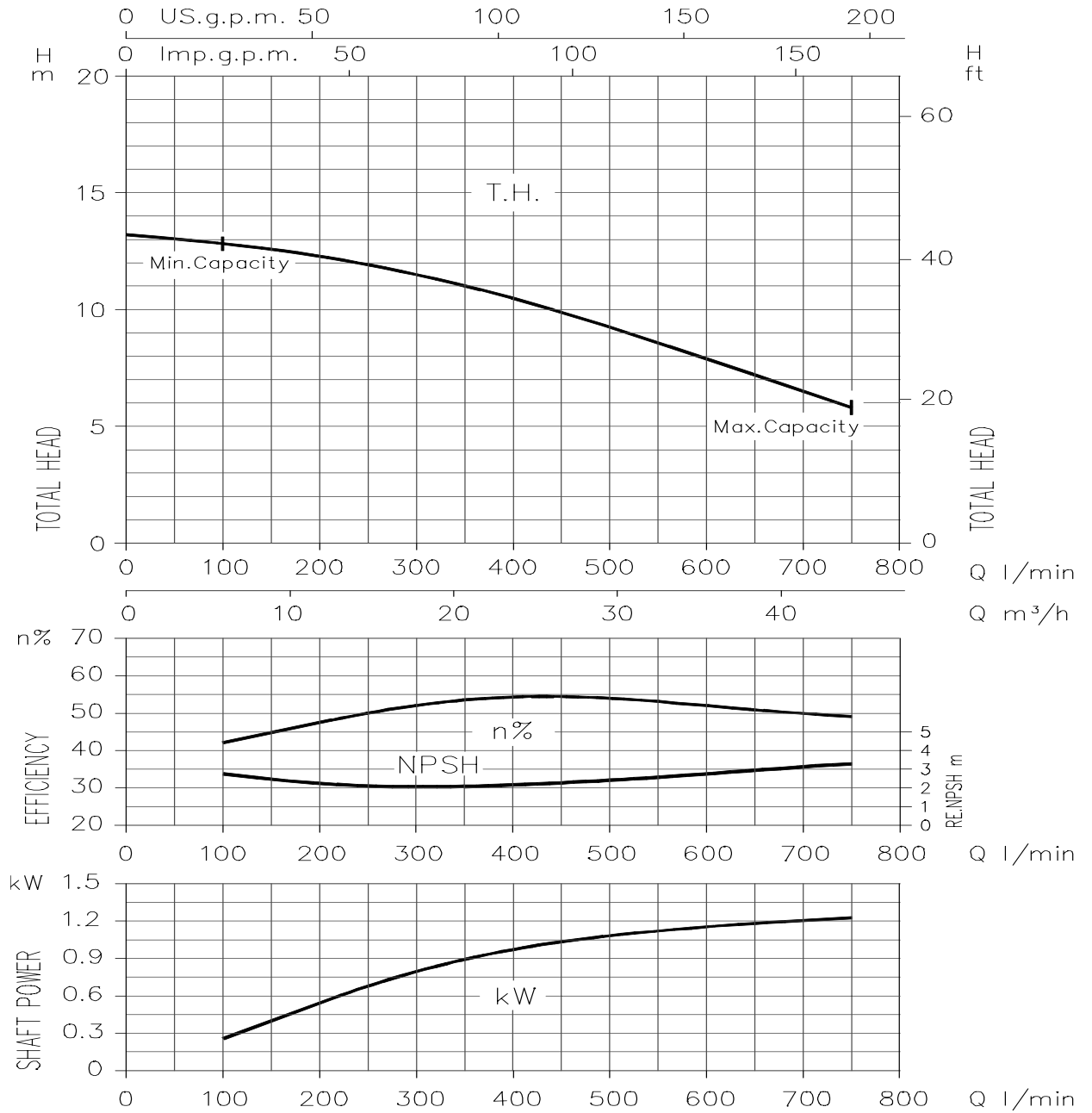

Rotation speed:  $\approx 2800 \text{ min}^{-1}$   
 Test fluid: clean water at 20°C  
 Applicable standard of test: ISO 9906 – Annex A

PERFORMANCE CURVES

50 Hz

DWO 300 (2.2 kW) - Impeller diameter = 107 mm

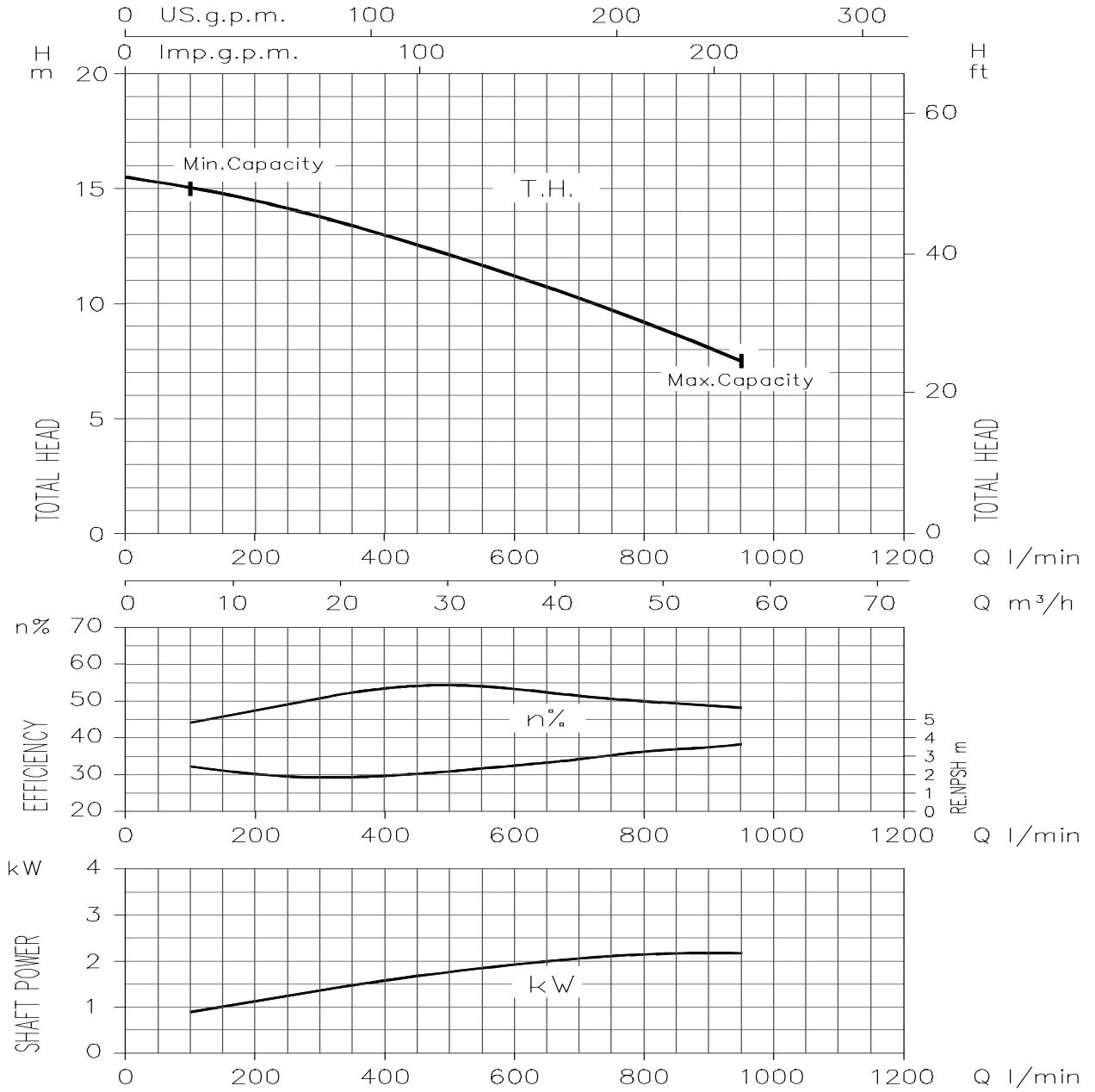

Rotation speed:  $\approx 2800 \text{ min}^{-1}$   
 Test fluid: clean water at  $20^\circ\text{C}$   
 Applicable standard of test: ISO 9906 – Annex A

DWO 400 (3 kW) - Impeller diameter: 118 mm

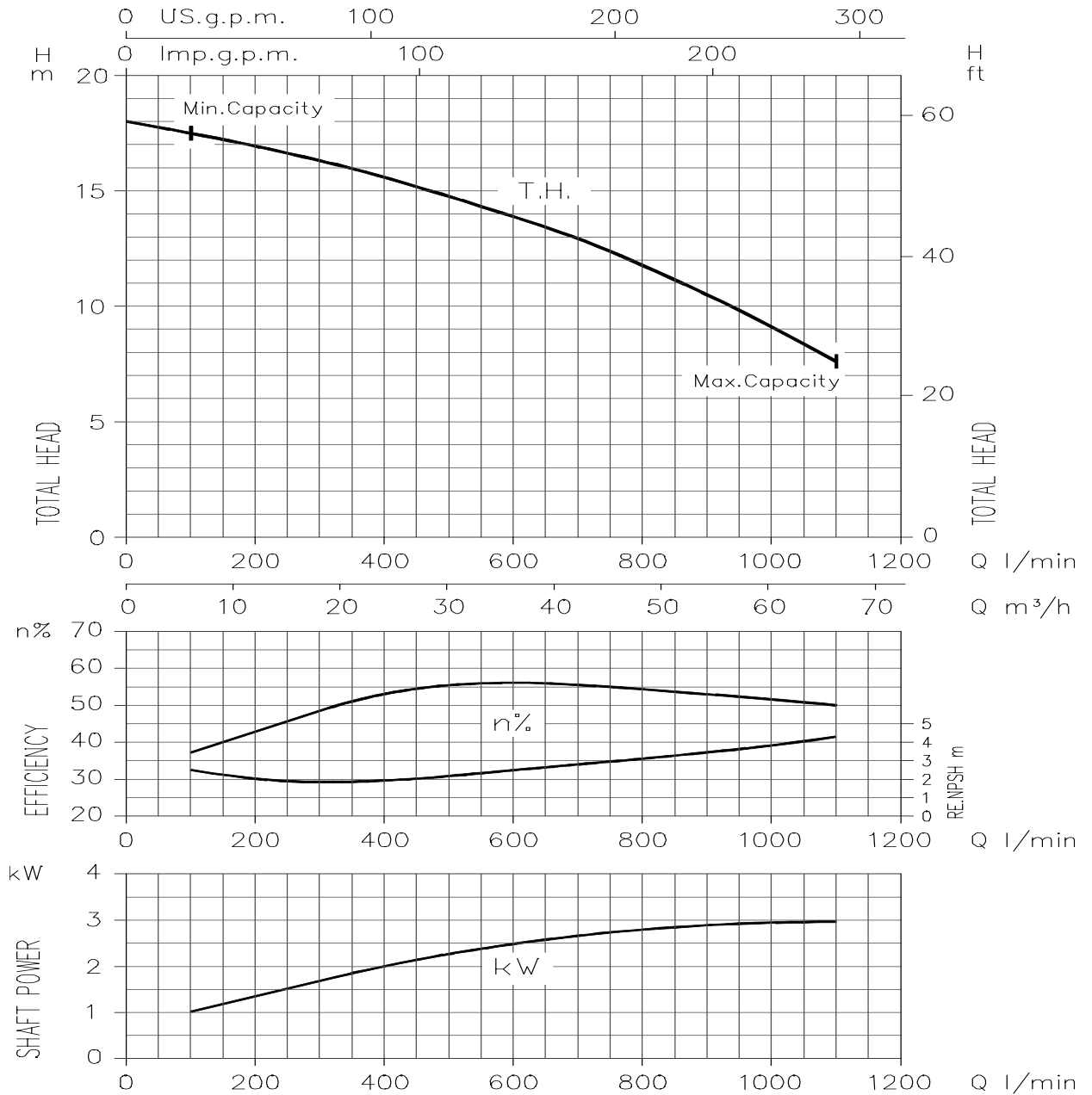

Rotation speed:  $\approx 2800 \text{ min}^{-1}$   
 Test fluid: clean water at  $20^\circ\text{C}$   
 Applicable standard of test: ISO 9906 – Annex A



SECTIONAL VIEW

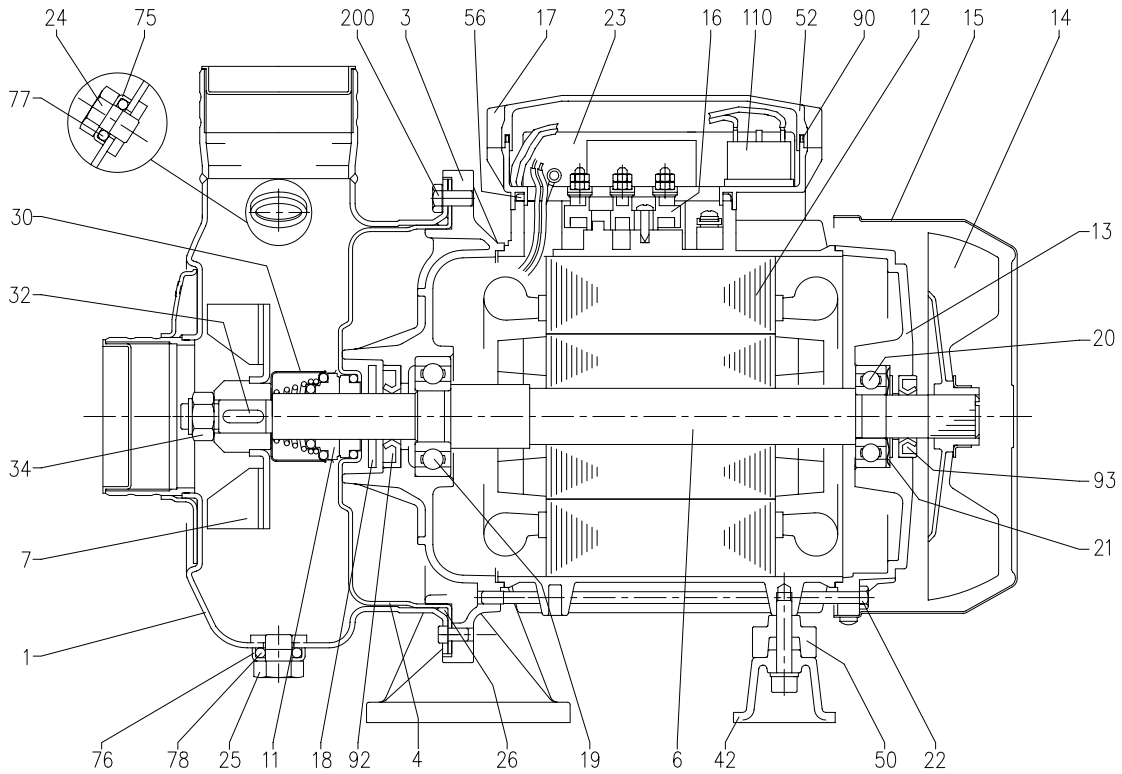

N°	PART NAME	MATERIAL	Q.TY	N°	PART NAME	MATERIAL	Q.TY
1	Casing	AISI304	1	25	Drain plug	AISI303	1
3	Motor bracket	Aluminium	1	26	O- ring	NBR	1
4	Casing cover	AISI304	1	30	Mechanical seal protection	AISI304	1
6	Shaft with rotor	AISI304 (Part in contact with liquid)	1	32	Key	AISI304	1
7	Impeller	AISI304	1	34	Impeller nut	AISI304	1
11	Mechanical seal [3]	Carbon/Ceramic/NBR	1	42	Motor support	Aluminium	1
12	Motor frame with stator	-	1	50	Spacer	-	1
13	Motor cover	Aluminium	1	52	Terminal box [1]	Polypropilene	1
14	Fan	Polypropilene	1	56	Box gasket	NBR	1
15	Fan cover	Fe P04 Zinked	1	75	Washer	AISI304	1
16	Terminal box	-	1	76	Washer	AISI304	1
17	Terminal box cover [2]	Aluminium	1	77	O- ring	NBR	1
18	Splash ring	NBR	1	78	O- ring	NBR	1
19	Pump side ball bearing	-	1	90	Covergasket [1]	NBR	1
20	Fan side ball bearing	-	1	92	Lip seal	-	1
21	Adjusting ring	Steel C70	1	93	Lip seal	-	1
22	Tie rod	Fe 42 Zinked	4	110	Protector [1]	-	1
23	Capacitor [1]	-	1	200	Screw	Stainless steel A2 UNF7323	6
24	Priming plug	AISI303	1				

[1] Only for single phase

[2] Only for three phase

[3] See constructions mechanical seal page 301

## MECHANICAL SEAL

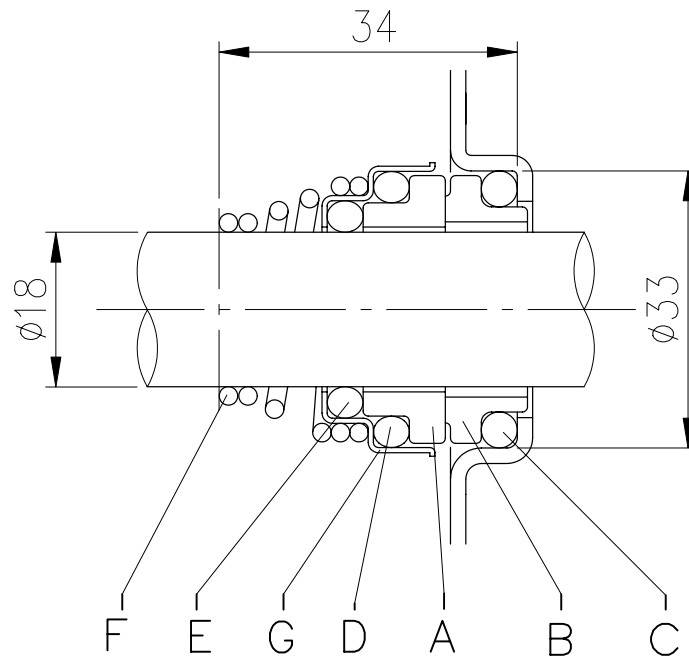

REF	PART NAME	MATERIAL product standard
		DWO
A	Rotary seal ring	ceramic
B	Stationary seal ring	carbon graphite
C	O Ring	NBR
D	O Ring	NBR
E	O Ring	NBR
F	Self driving spring	AISI 316
G	Frame	AISI 304

DIAGRAM AND ELECTRIC CONNECTIONS

SINGLE PHASE MOTOR

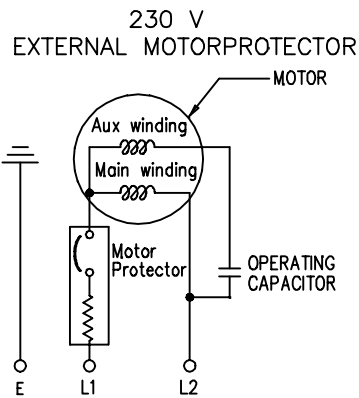
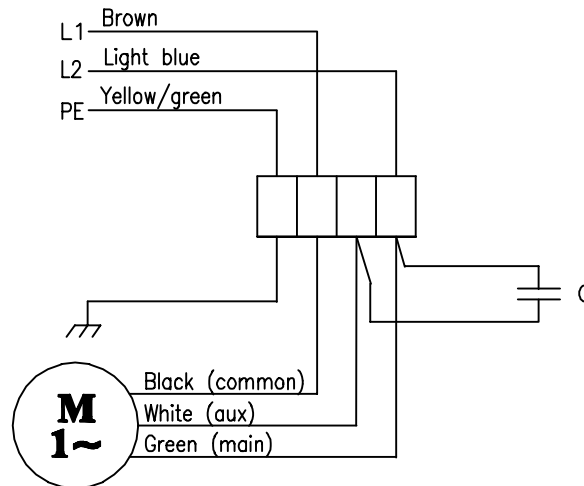
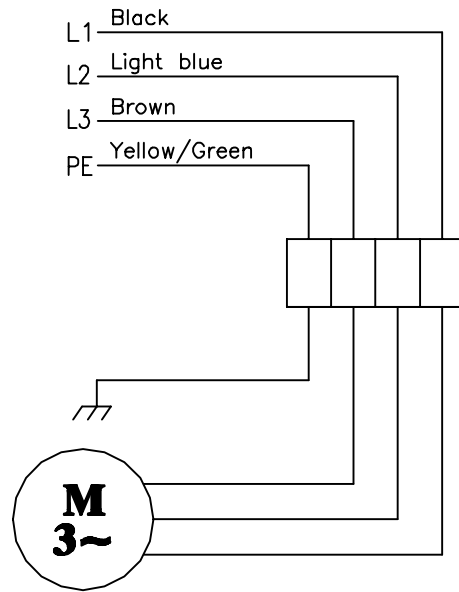

DIAGRAM AND ELECTRIC CONNECTIONS

THREE PHASE MOTOR



400 V  
STAR CONNECTION

230 V  
DELTA CONNECTION

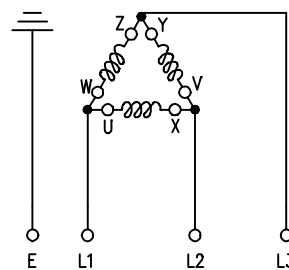
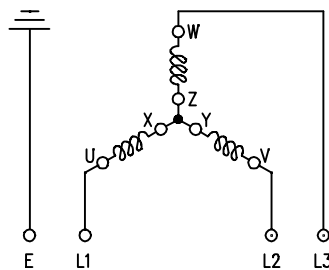

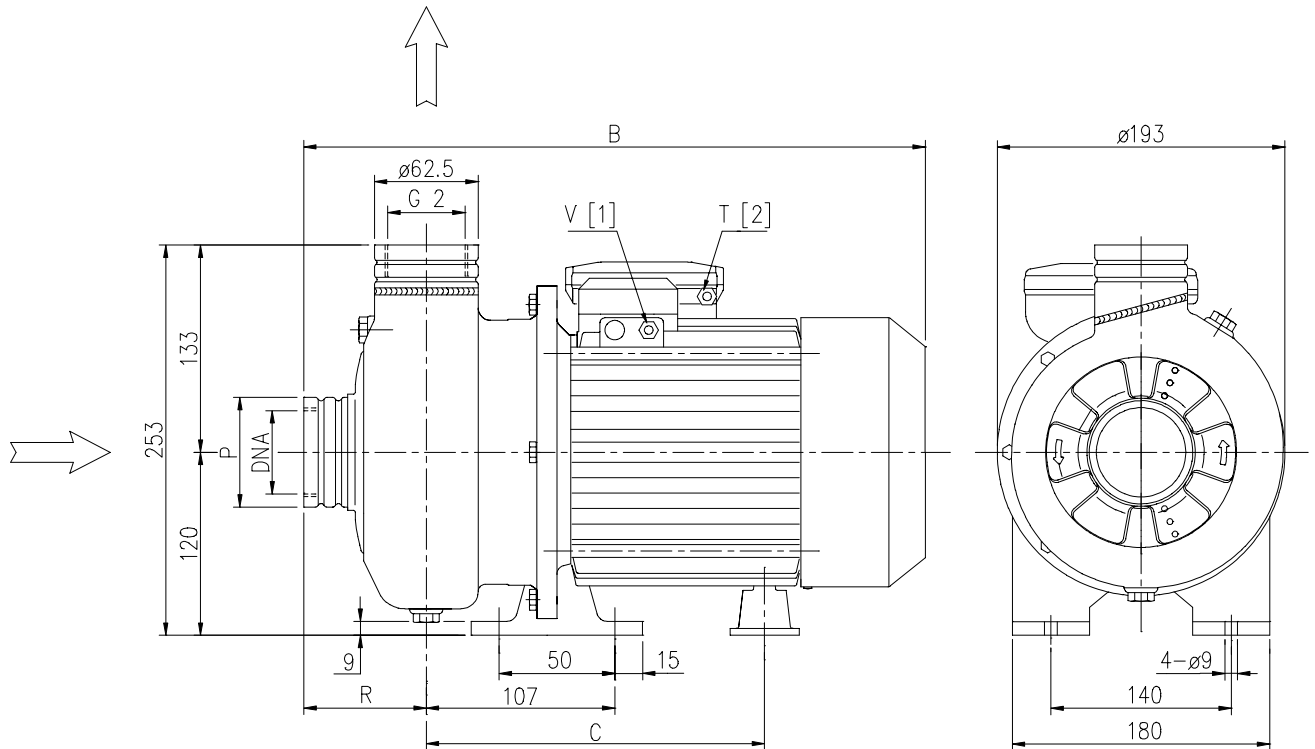

Pump type	Dimensions mm						
	B	C	R	Ø P	V	T	ØDNA
DWO 150	364	198.5	74	62.5	PG11	PG13.5	G 2
DWO 200	364	198.5	74	62.5	PG11	PG13.5	G 2
DWO 300	390	215.5	78	80	PG13.5	-	G 2½
DWO 400	415	240.5	78	80	PG13.5	-	G 2½

- [1] Three phase
- [2] Single phase

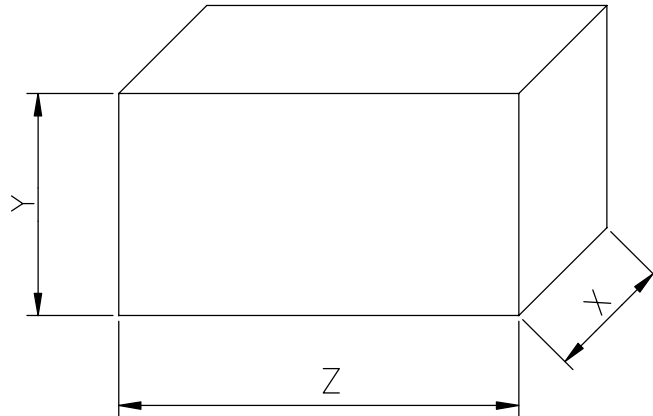

Type pumps		PACKING [mm]			WEIGHT [kg]	
Single Phase	Three Phase	X	Y	Z	Single Phase	Three Phase
DWO 150 M	DWO 150	432	205	280	13.6	12.6
DWO 200 M	DWO 200	432	205	280	15.7	14.4
-	DWO 300	432	205	280	-	16.9
-	DWO 400	432	205	280	-	20

Type pumps		kW	HP	Ball Bearing		Capacitor		Input in [kW]		Full load current in [A]		
Single Phase 230 V 50 Hz	Three Phase 230/400 V 50 Hz			Pump side	Fan side	Single Phase μF	VI	Single Phase	Three Phase	Single Phase	Three Phase 230 V   400 V	
DWO 150 M	DWO 150	1.1	1.5	6204 ZZ	6203 ZZ	31.5	450	1.36	1.25	6.8	4.4	2.5
DWO 200 M	DWO 200	1.5	2	6204 ZZ	6203 ZZ	40	450	2.05	2.0	9.0	6.1	3.5
-	DWO 300	2.2	3	6305 ZZ	6205 ZZ	-	-	-	2.7	-	8.3	4.8
-	DWO 400	3	4	6305 ZZ	6205 ZZ	-	-	-	3.7	-	11.0	6.4

Type pumps		Locked rotor current		
Single Phase 230 V 50 Hz	Three Phase 230/400 V 50 Hz	Single Phase 230 V 50 Hz	Three Phase 230 V   400 V 50 Hz	
DWO 150 M	DWO 150	36	38	22
DWO 200 M	DWO 200	43	48	28
-	DWO 300	-	58.9	34
-	DWO 400	-	95.3	55